

# Armour Exteriors & Interiors L.L.C.

**INVOICE #129**

**Updated 12/17/25**

**Date: 03/15/2025**

Carlos Hernandez  
7322 Greatwood

ITEM	DESCRIPTION		
1	ENTRY-Lightly sand and re coat all wood floors with Satin Polyurethane		
2	STUDY - Sand blemish in wood floor stain and add satin Polyurethane		
3	POWDER ROOM - fix damaged wood behind the toilet-stain-coat new counter top included.		
4	UTILITY ROOM - Clean tile & grout		
5	DINING ROOM - light sanding & re coat floor with satin Polyurethane		
6	BACK ENTRY - sand wood floor - stain & coat with satin Polyurethane		
7	Kitchen - lightly san wood floor - coat with satin Polyurethane		
8	Upstairs gameroom - light sand & coat with satin polyurethane All these lower areas had to be done so that floors would match	<b>items 1-8</b>	<b>\$7,800.00</b>
9	PAINT - paint all cabinets inside & out. Fix blemishes or water stains all walls and trim to be painted throughout home. All trim to be repaired and caulked prior to painting		<b>\$49,000.00</b>
10	Master bathroom - demo all shower and tub area - demo counter tops		<b>\$5,400.00</b>
11	New shower - shower tile - glass panel & door new undermount tub and quarts surrounds New counter top -existing floors to remain.		<b>\$29,000.00</b>
12	Option to remove wall paper in Master Bath - repair & Texture walls		<b>\$4,500.00</b>
13	Remove & replace the damaged paneling in the game room - stain and coat with satin polyurethane.		<b>\$6,500.00</b>
14	Remove grout on upstairs showers - regrout with new includes removal of green tile & install of white tile. Remove existing bathtub glass doors and install new Remove Damaged wall paper texture & Paint walls New counter tops included in the small bathrooms		<b>\$10,500.00</b>

# Armour Exteriors & Interiors L.L.C.

Date: 03/15/2025

**INVOICE #129**

Updated 12/17/25

Carlos Hernandez

7322 Greatwood

15	Replace mirrors in all bathrooms		\$3,500.00
16	Replace plumbing fixtures at bathroom sinks & tub/showers		\$3,500.00
17	Stair treads & railings - refinish/repaint the white balluster in white		\$3,000.00
18	New carpet at upstairs bedrooms and extra room		\$6,500.00
19	Paint garage ceiling amd walls.		\$2,500.00
20	Acid wash - seal cracks and Epoxy floors in garage - replace foam insulation on garage doors.		\$4,800.00
21	replace all exterior glass glazing that is damaged from Hail		\$2,500.00
22	touch up and paint exteriors soffits and fascia.		\$5,500.00
23	New counter top in game room option	\$1,000	\$1,000.00
24	paint existing wood panels or option to remove them - add sheetrock tape texture and paint.	\$5,000	\$5,000.00
25	Add wood plywood to attic floor to give additional support		\$600.00
		<b>TOTAL</b>	<b>\$151,100.00</b>

1ST DRAW	<b>PAID</b>	<b>-\$50,000.00</b>
2ND DRAW AFTER DEMO & wall panel install	<b>PAID</b>	<b>-\$35,000.00</b>
3RD DRAW AFTER FLOOR REFINSH	<b>PAID</b>	<b>-\$34,000.00</b>
4TH DRAW AFTER CARPET	<b>PAID</b>	<b>-\$20,100.00</b>
FINAL DRAW		<b>\$12,000.00</b>
Change Orders	<b>PAID</b>	<b>\$14,400.00</b>



2002 Timberloch Pl Suite 200 Spring, Tx 77380 Juan Cell: 936-206-1157

## Add Change Orders

12/17/2025

Carlos & Carmen Hernandez  
7322 Greatwood

	DESCRIPTION	TOTAL
1	New cabinet hardware throughout - knobs & handles	\$780.00
2	New passage door hardware - Doorknobs & Door stops	\$1,800.00
3	Added Light fixtures install - above tub & Fans homeowner pays for all fans & Light fixtures - sconces in master Juan purchases	\$1,500.00
4	New lights in the garage	\$300.00
5	Patch holes in the brick where old telecom was removed	\$300.00
6	remove and reseal silicon sealant at Butt windows by Breakfast area	\$150.00
7	Prep and paint all garage cabinets and peg boards and remove old Vacuum system - patch all holes	\$3,200.00
8	Install additional Plywood in the walk in attic.	\$600.00
9	Recoat waterproofing at upper concrete patio.	\$250.00
10	Verify all flood lights work and replace bulbs if needed	500 \$200.00
11	Tile for master Bathroom - materials only (Juan Paid for Install)	\$1,200.00
12	Wall tile across the back wall behind the tub - Materials & Labor	\$1,500.00
13	Remove damaged Insulation and spray loose insulation to bring attic up to R30 Value.	\$3,500.00
14	<b>Review item #13 for this added expense *THE \$350.00 WAS A TYPO &amp; COST = \$3,500.00*</b>	<b>\$3,150.00</b>
15	Replace damaged sprinkler back flow valves, Main shut of valve to the house. Install new hose bib by garage and fix all sprinklers	\$1,600.00
16	Haul off old regridgerator and dispose of	\$300.00
17	Replace all recessed lights with LED Trim lights & all outles & Switches	\$800.00
18	New Under cabinet outlets and lighting	\$950.00
19	New exterior entry locks & deadbolts	\$800.00
20	Modify Powder room lights and add sconces	\$600.00
21	Repair door thresholds and add new door seal at bottom	\$300.00
22	Repair exterior bricks at various locations	\$600.00
23	New carpet at stairs	\$1,800.00
24	Remove Old attic access ladder and sheetrock, Tape, Texture & paint	\$750.00
25	Replaced all ceiling fans & Lights throughout home - See noted comment on item #3	\$4,500.00
26	paint garage door frame on interior & replace the insulation(only outer pieces).	\$650.00
27	Remove old Tiles at fireplaces and install new material matching counter tops.	\$3,500.00
28	New Toilets in bathrooms including Powder	\$2,600.00
29	New lights in the closets	\$400.00
30	Replace damaged floor at 1st level-sand -stain & refinish floors \$4,500.00	\$1,400.00
<b>TOTAL</b>		<b>\$36,830.00</b>



Pool Deck  
7322 GREATWOOD

# INVOICE

Trident Pool Service and Pressure Wash  
Service Houston and all surrounding areas

tpoolservice@yahoo.com  
+1 (713) 836-9369

Carlos Hernandez

Bill to

6 Grand Manor Ct

Sugarland

Tx

77479

Ship to

6 Grand Manor Ct

Sugarland

Tx

77479

## Invoice details

Invoice no.: 4736

Invoice date: 02/21/2025

Due date: 03/23/2025

#	Date	Product or service	Description	Qty	Rate	Amount
1.	02/21/2025	Pool remodel	1. Demolish and disposal of all removed materials. 2. Remodel the entire deck pour concrete 800 sq ft with 4 inch thickness. 3. Rebar 12 inches, capacity for 4000 PSI- \$10.25 per sq fr. 4. Create 2 retention, 18 inches in and 18 inches out with a bench that is 18-20 feet long. 5. We will be adding coping in the color ivory light. It is 160 sq ft. 16x24 / 5cm. 6. Spray deck 1150 sq ft in the color ivory. 7. Add a drain of 4 inches and 30 feet in length. 8. Replace waterfall with natural wonders waterfall.	1	\$24,890.00	\$24,890.00

Total

**\$24,890.00**

Payment

-\$4,560.00

Balance due

**\$20,330.00**



2002 Timberloch Pl Suite 200, Spring, Texas 77380 Cell: 936-206-1157

INVOICE #144

10/23/2025

Carlos Hernandez  
7322 Greatwood

DESCRIPTION			
Remove stucco at bottom area where stucco texture is different and horizontal cracks are visible. Remove stucco around windows and decorative window/bands at attic height			\$15,700.00
Remove windows and flash per current codes to prevent water entry			
Re install same windows and then patch stucco and seal areas with construction sealant - Warranty for at least 5 years no leaks.			
Repairs will be hardly visible if at all.			
WE HAVE TO DRILL HOLES IN THE WEEP SCREEDS AT BOTTOM - THESE SHOULD NEVER HAD BEEN SEALED.			
The small upper window had been leaking and was removed. Decorative stucco design was installed in its place.			
The stucco band areas at Structural Beam only had to be patched.		Discount	-\$1,500.00
Structural beam was inspected and was not affected by the leak.			
This includes protecting all new pool decking and covering pool.			
<b>The Inside repairs which includes the paneling &amp; staining</b>			\$3,500.00
		<b>TOTAL</b>	<b>\$17,700.00</b>



FEL-WOODLANDS #2775  
 16590 INTERSTATE 45 S  
 STE 100  
 CONROE, TX 77384-4170  
 Phone: 936-273-0205  
 Fax: 936-273-9942

Deliver To:  
 From: Kenneth Jones  
 kenneth.jones2@ferguson.com  
 Comments:

15:14:27 AUG 27 2025

FERGUSON ENTERPRISES LLC #61

Price Quotation  
 Phone: 936-273-0205  
 Fax: 936-273-9942

**Bid No:** B732310  
**Bid Date:** 08/14/25  
**Quoted By:** CHJ

**Cust Phone:** 936-206-1157  
**Terms:** CASH ON DEMAND

**Customer:** AEI CONSTRUCTION  
 2002 TIMBERLOCK PLACE  
 SPRING, TX 77380

**Ship To:** AEI CONSTRUCTION  
 2002 TIMBERLOCK PLACE  
 SPRING, TX 77380

**Cust PO#:** HERNANDEZ

**Job Name:** COOKTOP + DOWNDRAFT

Item	Description	Quantity	Net Price	UM	Total
KKCGS356ESS	( KITCHENAID OPT 1) CCY SS 36 5 BRNR GAS CKTP W/ CI GRA	1	1298.000	EA	1298.00
B273603	( BROAN DOWNDRAFT ) CCY 36 D/DRAFT W/ CVR SS	1	784.450	EA	784.45
	----				
;FACCT	CKTP INSTALL	1	125.000	EA	125.00
;FAVDDH	D/DRAFT HOOD INSTALL	1	350.000	EA	350.00
;FAMPRE	JOB PRE SITE	1	85.000	EA	85.00
<b>Net Total:</b>					\$2642.45
<b>Tax:</b>					\$171.81
<b>Freight:</b>					\$0.00
<b>Total:</b>					\$2814.26

Quoted prices are based upon receipt of the total quantity for immediate shipment (48 hours). SHIPMENTS BEYOND 48 HOURS SHALL BE AT THE PRICE IN EFFECT AT TIME OF SHIPMENT UNLESS NOTED OTHERWISE. QUOTES FOR PRODUCTS SHIPPED FOR RESALE ARE NOT FIRM UNLESS NOTED OTHERWISE.

Due to the uncertain impact of potential tariffs, Ferguson's quotation/proposal has not included any provision or contingency for future tariffs or increase of existing tariffs. Ferguson reserves the right to adjust prices to reflect the impact of any new or increased tariffs that affect our costs at the time of shipment. Ferguson will provide notice of any such adjustments along with documentation supporting the changes.

CONTRACTOR CUSTOMERS: IF YOU HAVE DBE/MBE/WBE//VBE/SDVBE/SBE GOOD FAITH EFFORTS DIVERSITY GOALS/ REQUIREMENTS ON A FEDERAL, STATE, LOCAL GOVERNMENT, PRIVATE SECTOR PROJECT, PLEASE CONTACT YOUR BRANCH SALES REPRESENTATIVE IMMEDIATELY PRIOR TO RECEIVING A QUOTE/ORDER.

Seller not responsible for delays, lack of product or increase of pricing due to causes beyond our control, and/or based upon Local, State and Federal laws governing type of products that can be sold or put into commerce. This Quote is offered contingent upon the Buyer's acceptance of Seller's terms and conditions, which are incorporated by reference and found either following this document, or on the web at <https://www.ferguson.com/content/website-info/terms-of-sale>

Govt Buyers: All items are open market unless noted otherwise.

LEAD LAW WARNING: It is illegal to install products that are not "lead free" in accordance with US Federal or other applicable law in potable water systems anticipated for human consumption. Products with \*NP in the description are NOT lead free and can only be installed in non-potable applications. Buyer is solely responsible for product selection. Buyer shall accept delivery of products within 60 days of Seller receiving the products at Seller's warehouse. If Buyer causes or requests a delay in delivery of the products, Buyer may be subject to storage fees and additional costs caused by such delay. Seller reserves the right to requote the products and reschedule the delivery date, subject to manufacturer's lead times and price increases, if Buyer is unable to accept delivery within 60 days.



**HOW ARE WE DOING? WE WANT YOUR FEEDBACK!**

Scan the QR code or use the link below to complete a survey about your bids:

<https://survey.medallia.com/?bidsorder&fc=190&on=464809>

15:14:27 AUG 27 2025  
Reference No: B732310



**HOW ARE WE DOING? WE WANT YOUR FEEDBACK!**

Scan the QR code or use the link below to  
complete a survey about your bids:

<https://survey.medallia.com/?bidsorder&fc=190&on=464809>



**Estimate #143**

2002 Timberloch PI Suite 200, Spring, Texas 77380 Cell: 936-206-1157

**Date: 07/26/2025**

Carlos & Carmen Hernandez  
7322 Greatwood

ITEM	DESCRIPTION		
1	New balcony railing		<b>\$1,600.00</b>
2	Railing to be powder coated in color Black		
3	Anchor points will have sealant added prior to installing anchors		
<b>TOTAL</b>			<b>\$1,600.00</b>

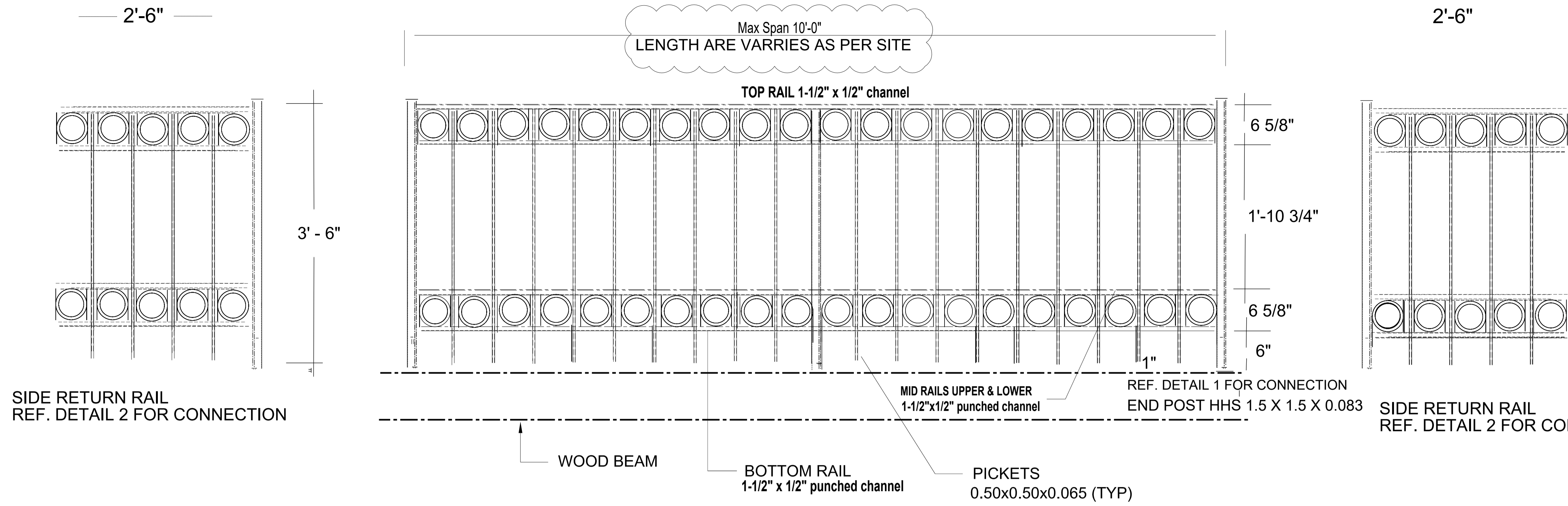

SIDE RETURN RAIL  
REF. DETAIL 2 FOR CONNECTION

SIDE RETURN RAIL  
REF. DETAIL 2 FOR CONNECTION

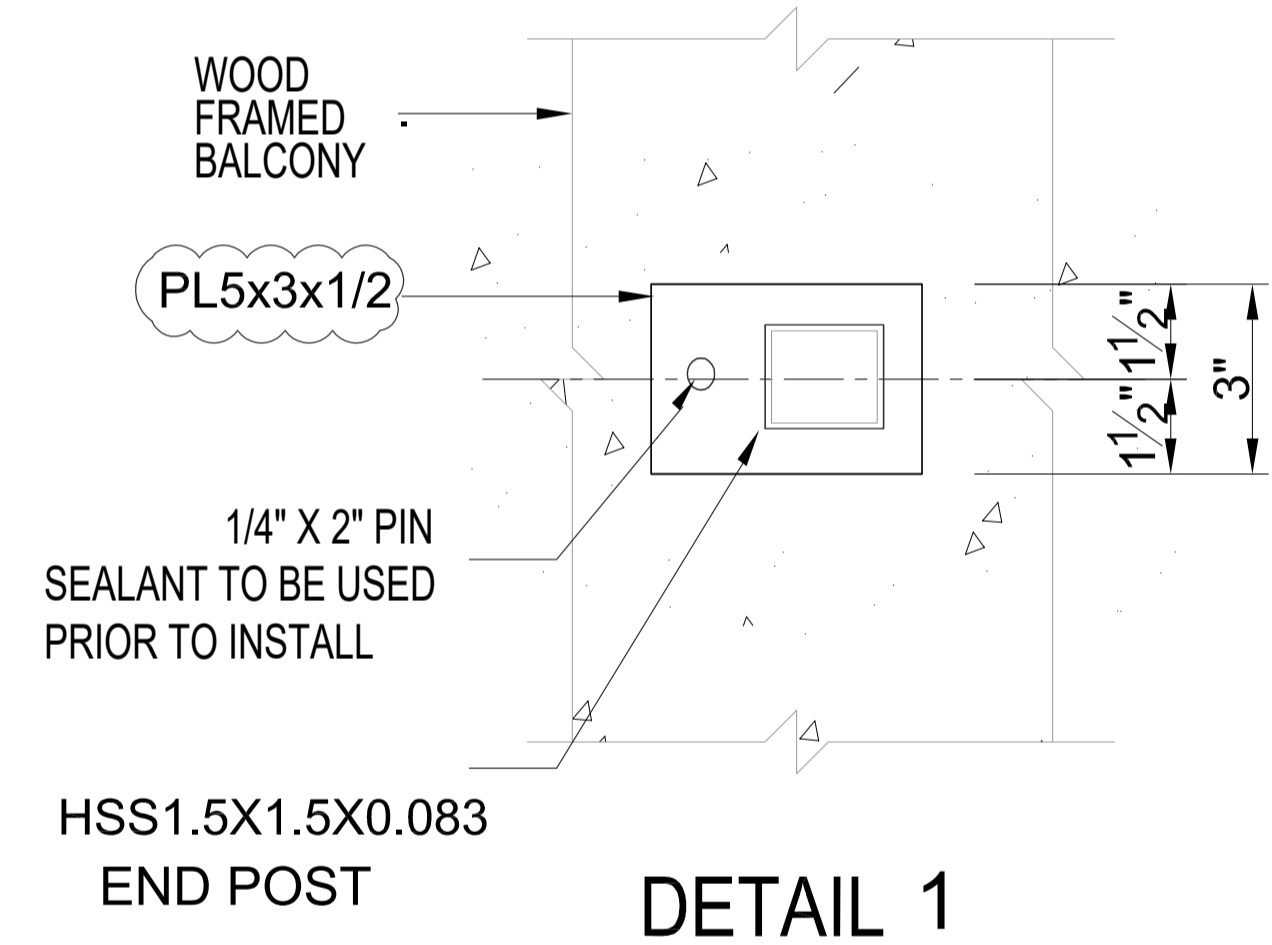

DETAIL 1

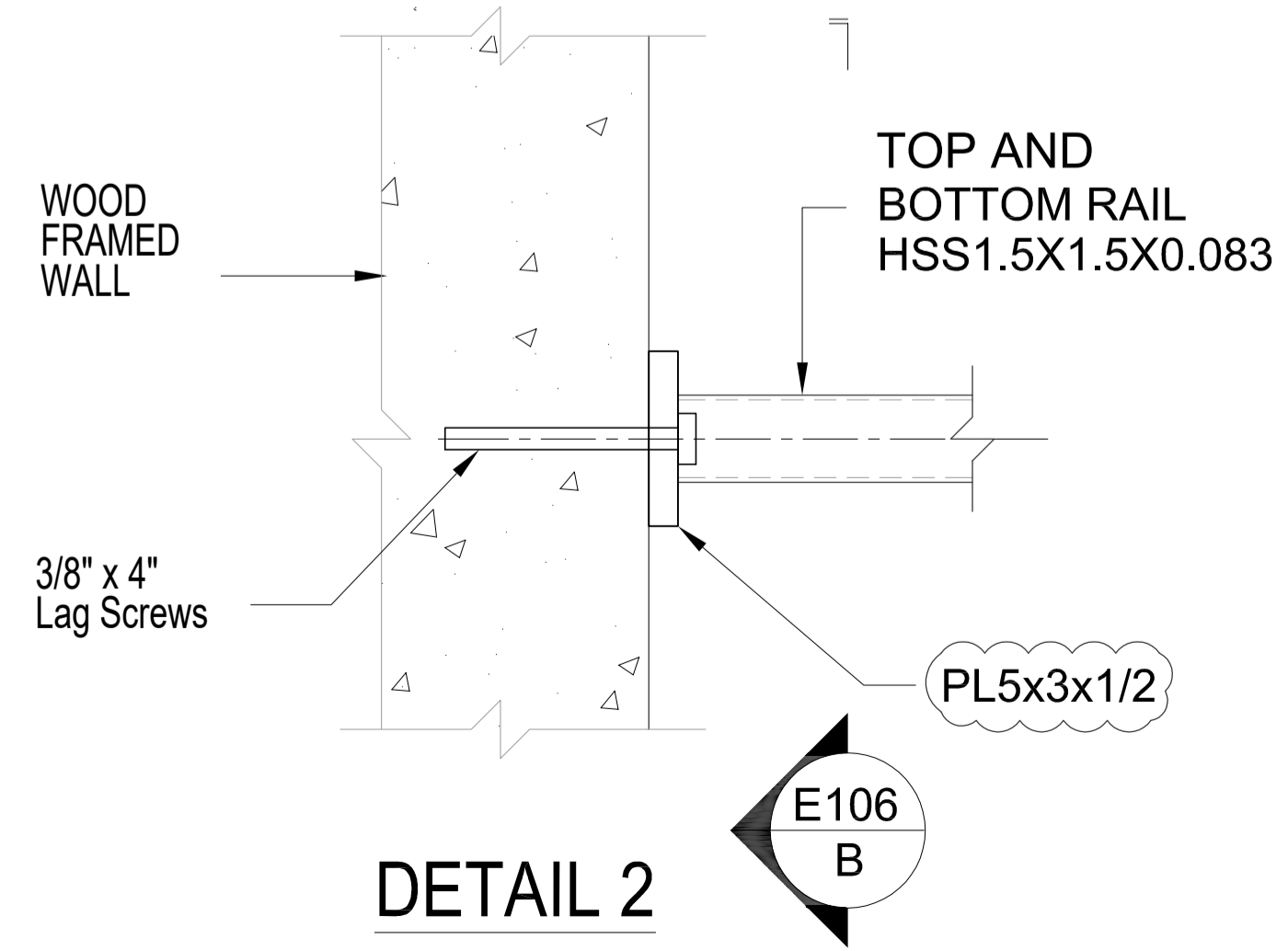
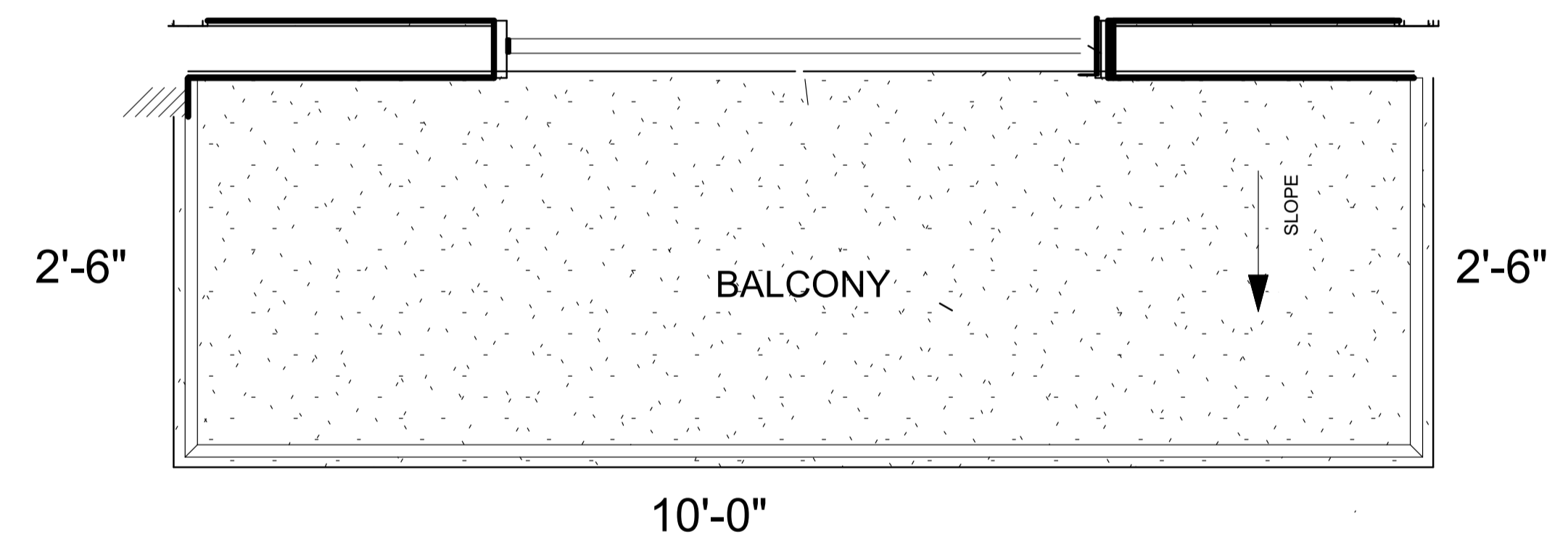

DETAIL 2

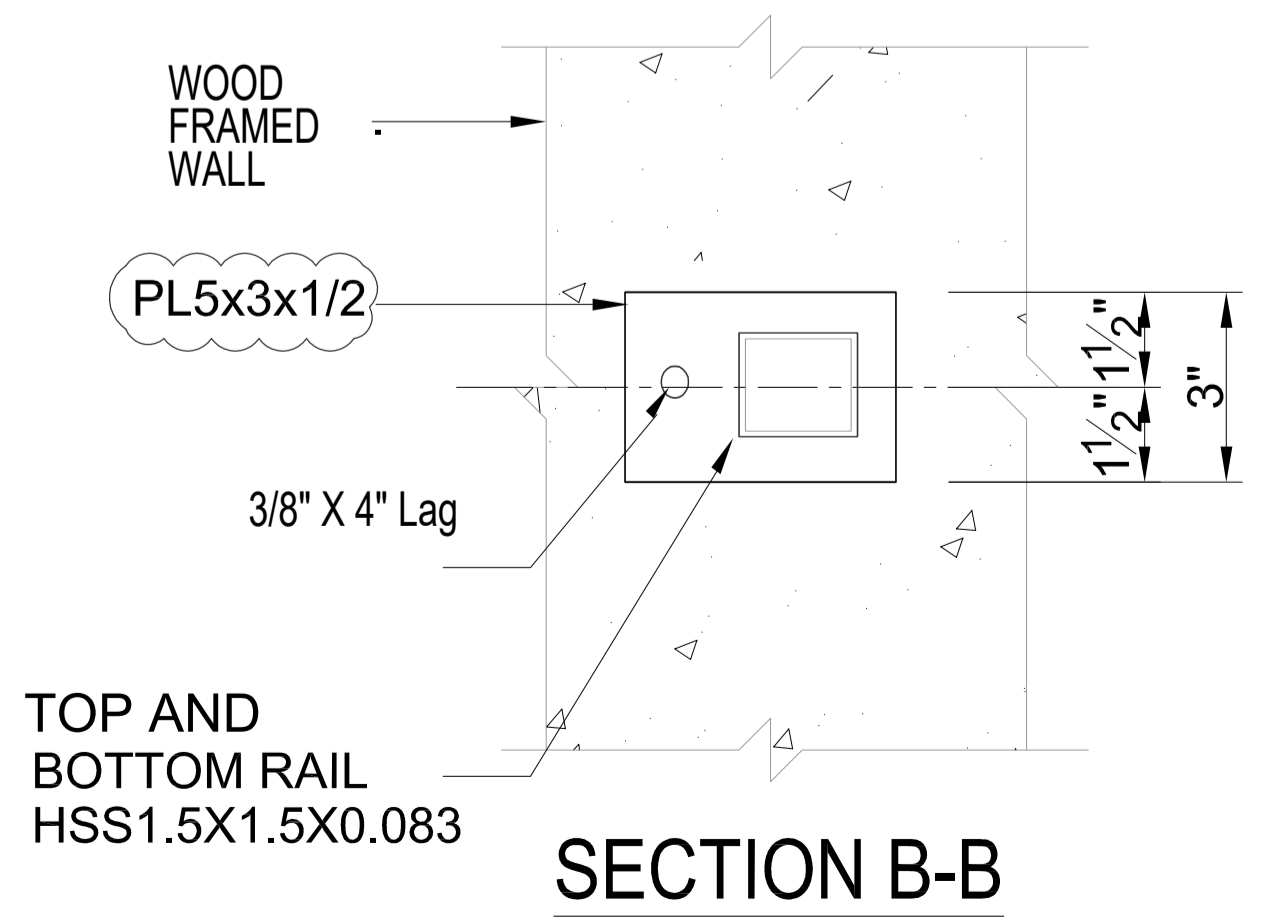

SECTION B-B

- 1) TO BE FABRICATE AS PER LAYOUT & FIELD REQUIREMENTS.
- 2) NOTE FOR CONTRACTOR :- TO BE LOCATE AS PER FIELD REQUIREMENTS

DATE	NO	BY	FOR
08/16/2025	0	JJJ	ISSUED FOR CONSTRUCTION
08/01/2025	1	JJJ	ISSUED FOR APPROVAL
07/28/2025	0	JJJ	ISSUED FOR APPROVAL

STEEL : ASTM A36	U.N.O.	DRAWN BY: JJJ	DATE: 7/28/2025
WELDING ELECTRODES : E70XX	U.N.O.		
WELDS : 3/16 FILLET	U.N.O.		
OPEN HOLES : 13/16"Ø	U.N.O.		
BOLTS :	U.N.O.		
PAINT :	U.N.O.		

**AEI STEEL**  
2002 Timberloch Pl, Suite 200 Spring, Tx 77380

DETAILS OF: FALSE BALCONY RAIL

CUSTOMER: CARLOS & CARMEN HERNANDEZ  
PROJECT: HERNANDEZ BALCONY RAIL  
LOCATION: 7322 GREATWOOD LAKE DR.

JOB NO.  
SHEET NO. E101  
0  
REV. NO.

